

THIS DRAWING IS COPYRIGHT © CAMBRIA CONSULTING LTD.
DO NOT SCALE FROM THIS DRAWING.
CONTRACTORS MUST CHECK ALL DIMENSIONS ON SITE. ONLY FIGURED DIMENSIONS ARE TO BE WORKED FROM. DISCREPANCIES MUST BE REPORTED IMMEDIATELY TO CAMBRIA CONSULTING LIMITED BEFORE PROCEEDING.
THE CONTRACTOR IS TO REFER TO THE SPECIFICATION, FULL SCHEDULE OF RESIDUAL RISKS IN THE CONTRACT DOCUMENTATION AND ALSO TO INFORMATION FROM OTHER DESIGNERS, IN PARTICULAR THE M&E CONSULTANT REGARDING EXISTING LIVE SERVICES.
 THIS SYMBOL IS USED TO HIGHLIGHT INSTANCES OF RISK WITHIN THE CONSTRUCTION PROCESS.
ALWAYS CHECK FOR LATER REVISIONS OF THIS DRAWING.

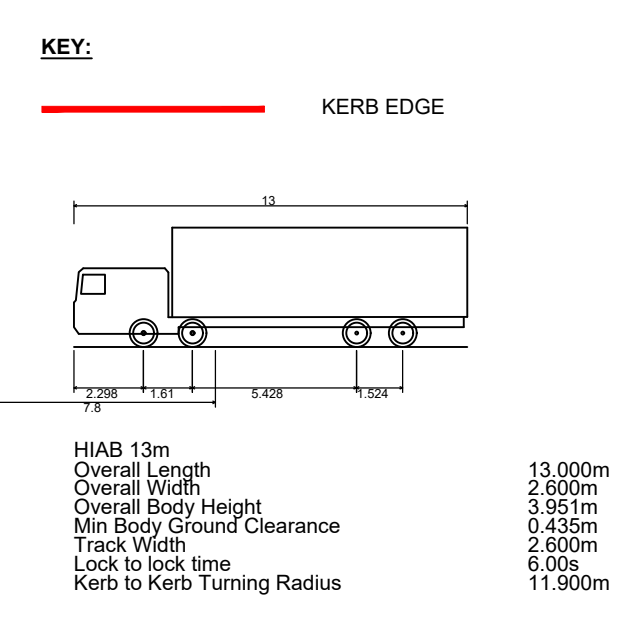

NOTE:
HIAB 13m IS AN EDITED VERSION OF RIGID TRUCK FROM VEHICLE TRACKING LIBRARY. FOR ACCURATE ANALYSIS FULL VEHICLE INFORMATION MUST BE SUPPLIED.

INSET 1 - HIAB 13m
(REVERSE SOUTHERN SIDE)
1:250

INSET 2 - HIAB 13m
(REVERSE NORTHERN SIDE)
1:250

P01	FIRST ISSUE.	LW	BW	BW
Rev.	Description	By	Chk	App
				22/07/24

Client:
MORGAN SINDALL

Project:
**PEN Y DRE
COMPREHENSIVE SCHOOL
CC2268**

Drawing Title:
**PV ARRAY
SWEEP PATH ANALYSIS
(HIAB)**

Drawing No.
26Z006 CAM XX XX DR C 5001

Status	Originator	Vol.	Level	Type	Role	Number
S1	PRELIMINARY					P01

CAMBRIA
Constructive Thinking

Civil & Structural Engineers T 029 2099 3333
Cambria House E admin@cambria.co.uk
16 Plas St, Poi de Leon W www.cambria.co.uk
Penarth Marina @cambriauk
Cardiff, CF64 1TR uk.linkedin.com/in/cambriauk