

NOTES

- GENERAL
1. ALL DIMENSIONS ARE IN MILLIMETRES UNLESS NOTED OTHERWISE.
 2. ALL LEVELS ARE IN METRES UNLESS NOTED OTHERWISE.
 3. ALL LEVELS RELATE TO ORDNANCE DATUM UNLESS NOTED OTHERWISE.
 4. DO NOT SCALE FROM THIS DRAWING. USE FIGURED DIMENSIONS ONLY.
 5. ANY DISCREPANCIES TO BE REPORTED IMMEDIATELY TO THE ENGINEER.
 6. THIS DRAWING TO BE READ IN CONJUNCTION WITH ALL RELEVANT ARCHITECTS, SUBCONTRACTORS AND SPECIALISTS DRAWINGS AND SPECIFICATIONS.
 7. THIS DRAWING IS COPYRIGHT © INTRADO CONSULTING ENGINEERS LTD.
 8. TOPOGRAPHICAL SURVEY UNDERTAKEN BY LANDMARK SURVEYS WALES, JOB REFERENCE 6581 DATED APRIL 2023
 9. ENGINEERING BASED ON ARCHITECTURAL SITE LAYOUT BY MORGAN 2 MORGAN ARCHITECTS JOB No. 4444.

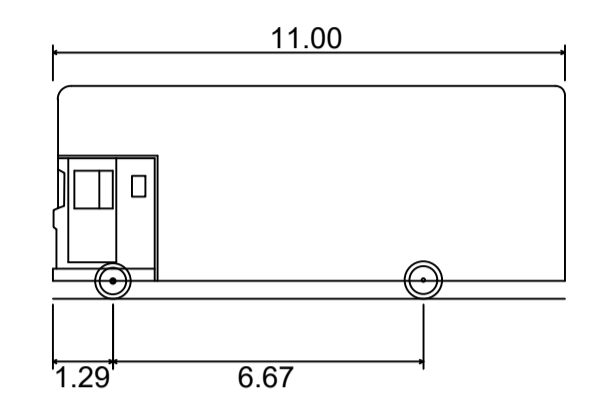
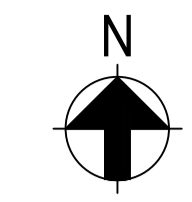

DB32 Pantechnicon 11m	
Overall Length	11.000m
Overall Width	2.520m
Overall Body Height	4.571m
Min Body Ground Clearance	0.383m
Max Track Width	2.300m
Lock to lock time	6.00s
Kerb to Kerb Turning Radius	10.450m

LEGEND

- VEHICLE CHASSIS/ WHEEL ENVELOPE
- VEHICLE BODY ENVELOPE

SITE GRID REFERENCE: S5817766
(281785mE, 176695mN)

FOUL & SURFACE WATER DRAINAGE SUBJECT TO S104 & S106 APPROVALS
HIGHWAY WORKS SUBJECT TO BRIDGEND COUNTY BOROUGH COUNCIL S278 APPROVAL
ANY WORKS CARRIED OUT PRIOR TO THE ISSUE OF RELEVANT APPROVALS ARE ENTIRELY AT THE DEVELOPER'S RISK

P1	S78 PROPOSALS AMENDED. EXISTING LOADING BAY TO REMAIN	KMG	09.07.2023
REV.	DESCRIPTION	BY	DATE



UNIT C
Upper Boat Business Centre
Pontypridd CF37 5EP
tel: 02920 811097
web: www.intrado.co.uk
e-mail: admin@intrado.co.uk

client
EASY LIVING LTD

project
THE PORTHCAWL HOTEL

drawing title
REFUSE VEHICLE SWEEP PATH ANALYSIS

drawn	KMG	chd	CC	scale	1:100 @ A1	date	AUG 2023
-------	-----	-----	----	-------	------------	------	----------

Preliminary	<input checked="" type="checkbox"/>	Job No.	INT22155	Drawing No.	003	Rev.	0
Tender	<input type="checkbox"/>						
Construction	<input type="checkbox"/>						

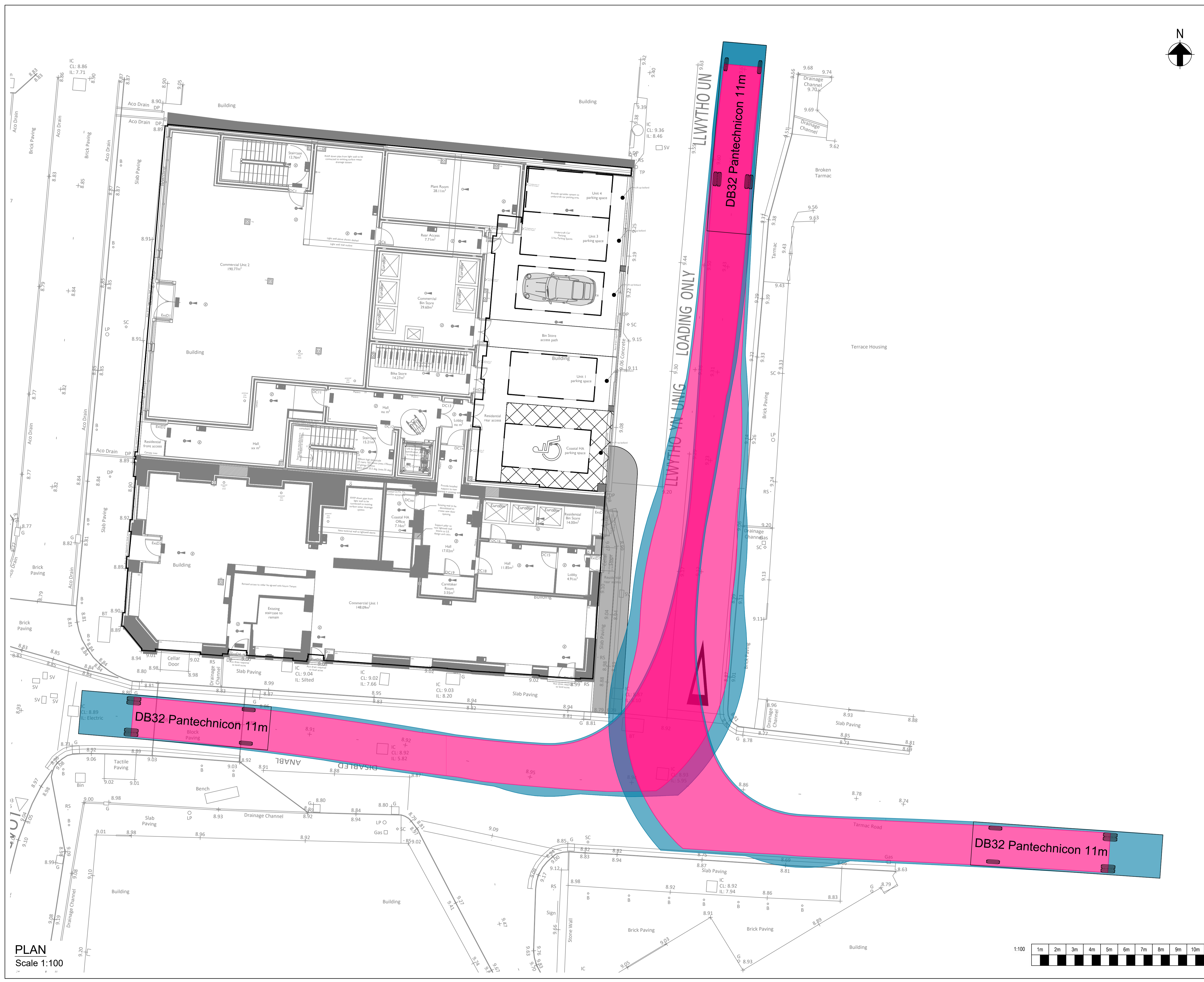

PLAN
Scale 1:100

