

FIRST FLOOR BATHROOM
[LTH CRITERION 14]

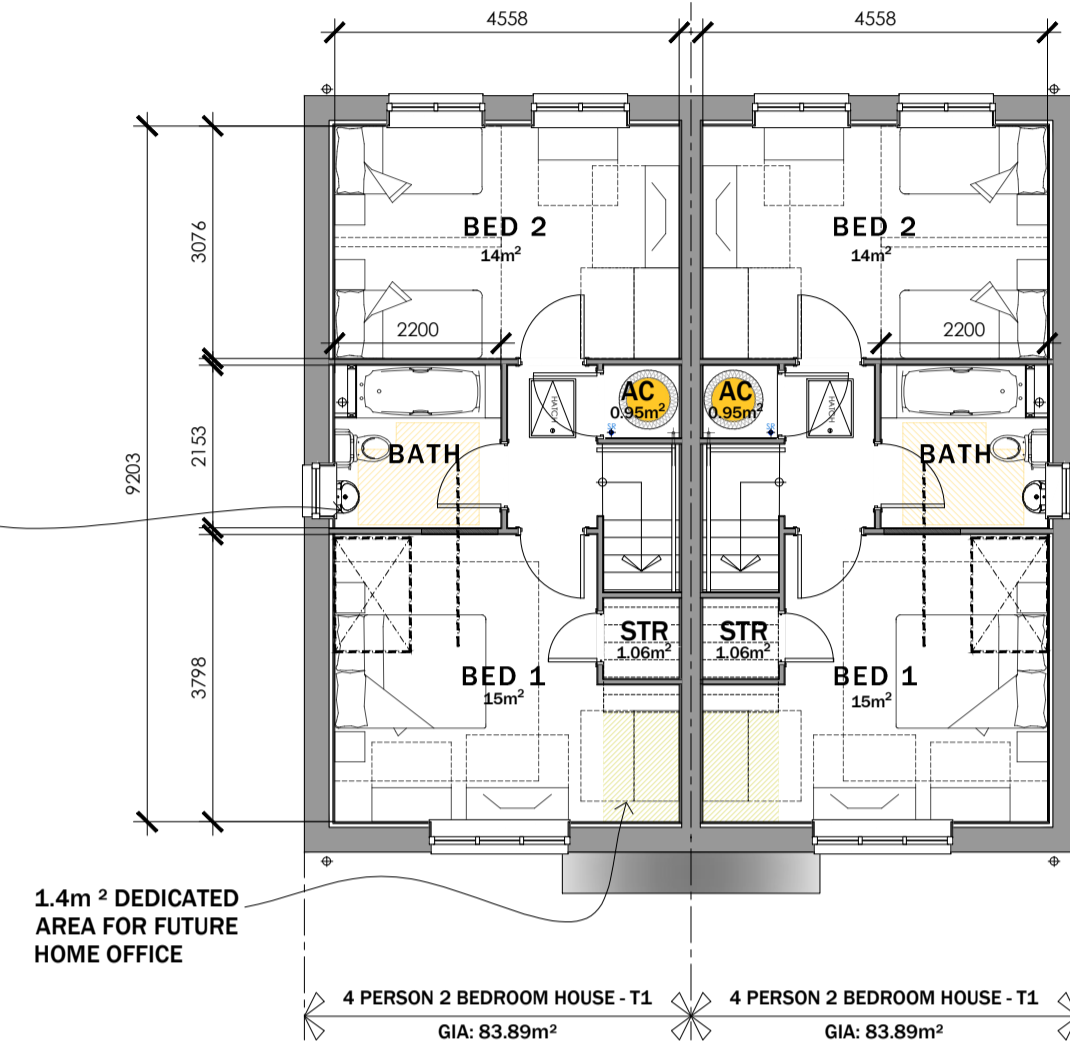

FIRST FLOOR PLAN

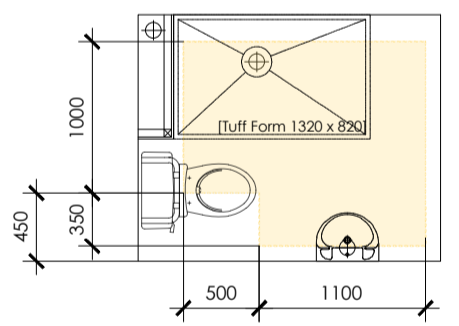

GROUND FLOOR ACCESSIBLE WC
[LTH CRITERION 14]

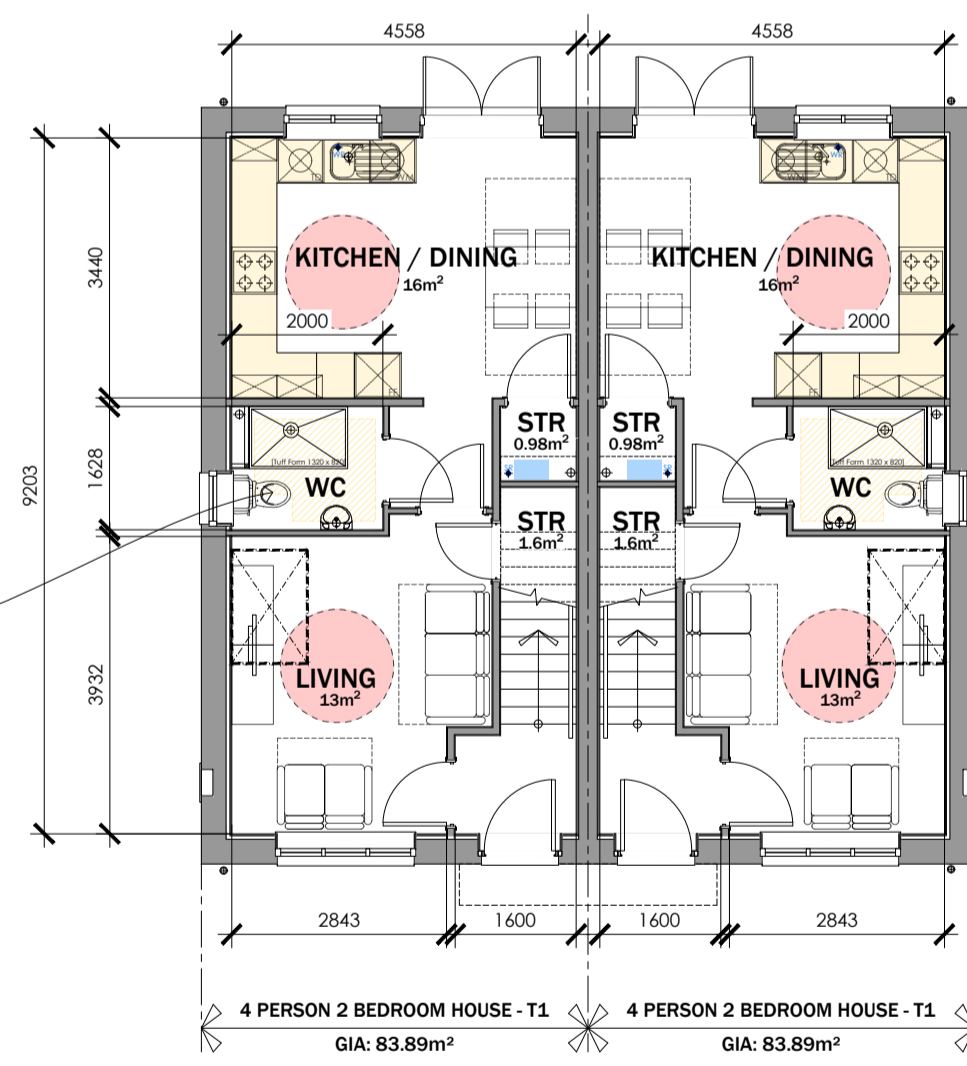

GROUND FLOOR PLAN

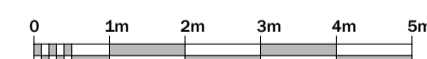

STORAGE SCHEDULE:

4P2B HOUSE TYPE 1
 GROUND FLOOR:
 STORE: 0.99M²
 U/S STAIRS: 1.60M²
 FIRST FLOOR:
 AC: 0.95M²
 STORE: 1.06M²

TOTAL STORAGE PROVIDED - 4.59M²
 TOTAL STORAGE REQUIRED - 2.5M²
 TOTAL STORAGE EXCESS - 2.09M²

MATERIAL KEY LEGEND

- 1 RECONSTITUTED SLATE ROOF FINISHES - DARK RED
- 2 WHITE UPVC FASCIAS, SOFFITES AND BARGEBOARDS WITH BLACK RAINWATER GOODS
- 3 WHITE UPVC DOUBLE GLAZED WINDOWS AND REAR DOOR UNITS
- 4 CREASING TILE BRICK CILL
- 5 GRP PORCH CANOPY OVER
- 6 PREFABRICATED FLAT GAUGE BRICK ARCH IN SMOOTH DARK RED BRICKWORK
- 7 FACING BRICKWORK
- 8 PROJECTING BRICK FEATURE BAND AT 750MM ABOVE FFL IN SMOOTH DARK RED BRICK.
- 9 SOLDIER COURSE CILLS AND HEADS
- 10 ROUGH CAST RENDER FINISH COLOUR: OFF WHITE
- 11 GRP COMPOSITE FRONT ENTRANCE DOORS COLOUR: TBC



FRONT ELEVATION

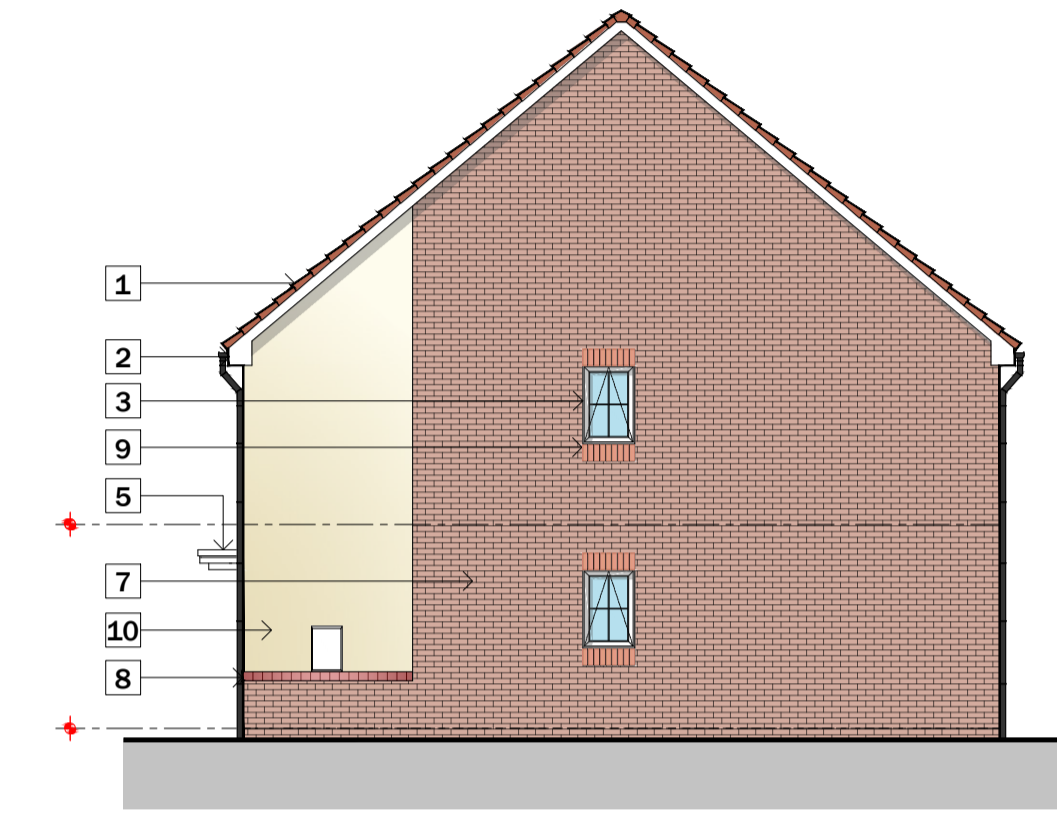

SIDE ELEVATION



REAR ELEVATION

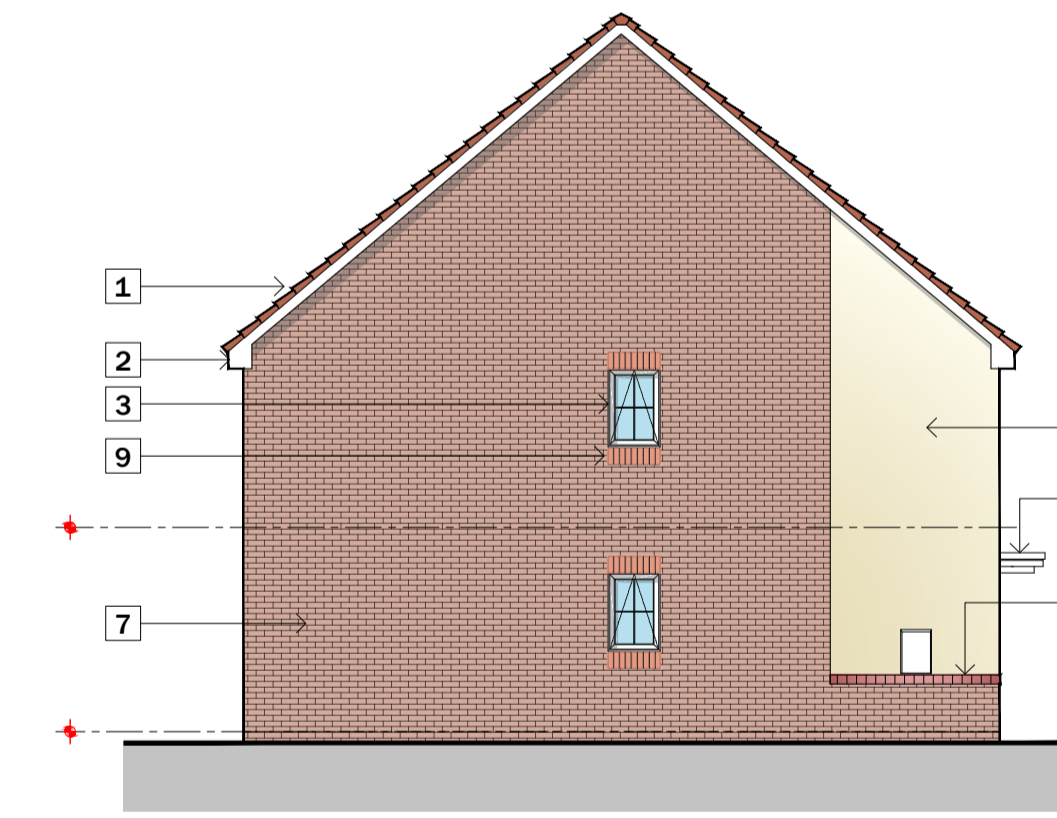

SIDE ELEVATION

Do not scale from this drawing. The users of this drawing shall check all dimensions and details against the design and specifications and shall be responsible for any omissions to LeTrucco Design.
 This drawing is copyright. It must not be reproduced, stored in a retrieval system or transmitted in any form or by any means, electronic, mechanical, photocopying, recording or otherwise, without prior permission of LeTrucco Design.

Revisions
 REV.A AUG 24
 SMALL ADJUSTMENTS TO ELEVATIONS

Drawing No	Revision	Scale	Date	Checked
LT2410.04.200	A1	1:100 @ A1	Aug 24	KWL
Job Title				
Land off Hirwaun Road				

Drawing Purpose
 PLANNING

4P 2B HOUSE TYPES 1 Plots 4 - 5 + 16 - 17
 G.I.A = 83.89m² / 902.98 ft²