

FIRST FLOOR BATHROOM
[LTH CRITERION 14]

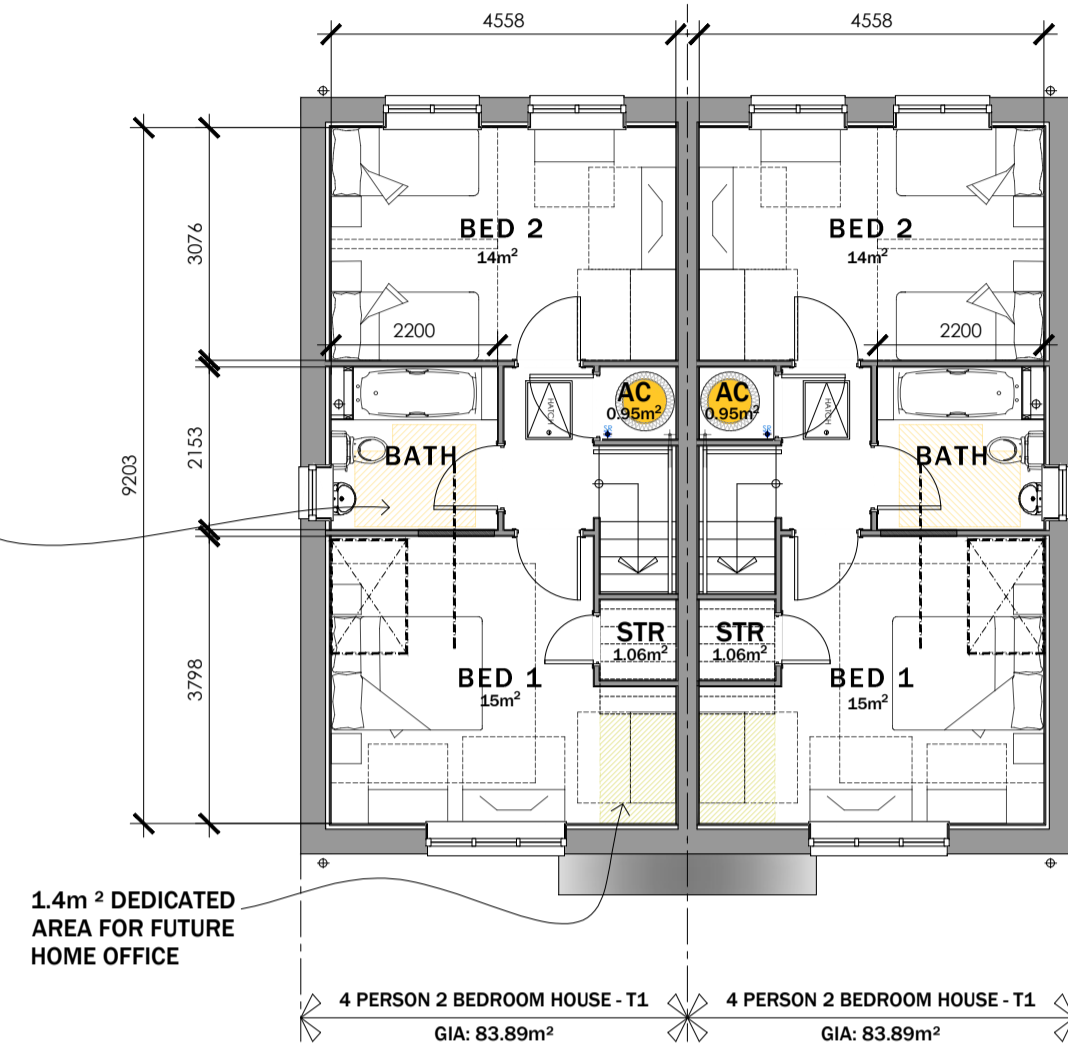

1.4m² DEDICATED
AREA FOR FUTURE
HOME OFFICE

FIRST FLOOR PLAN

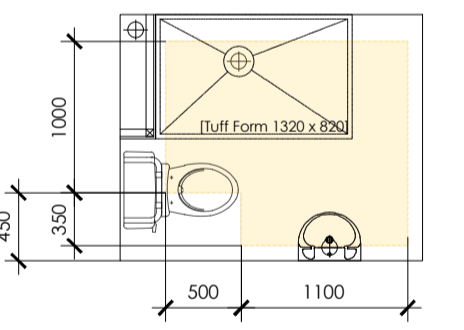

GROUND FLOOR ACCESSIBLE WC
[LTH CRITERION 14]

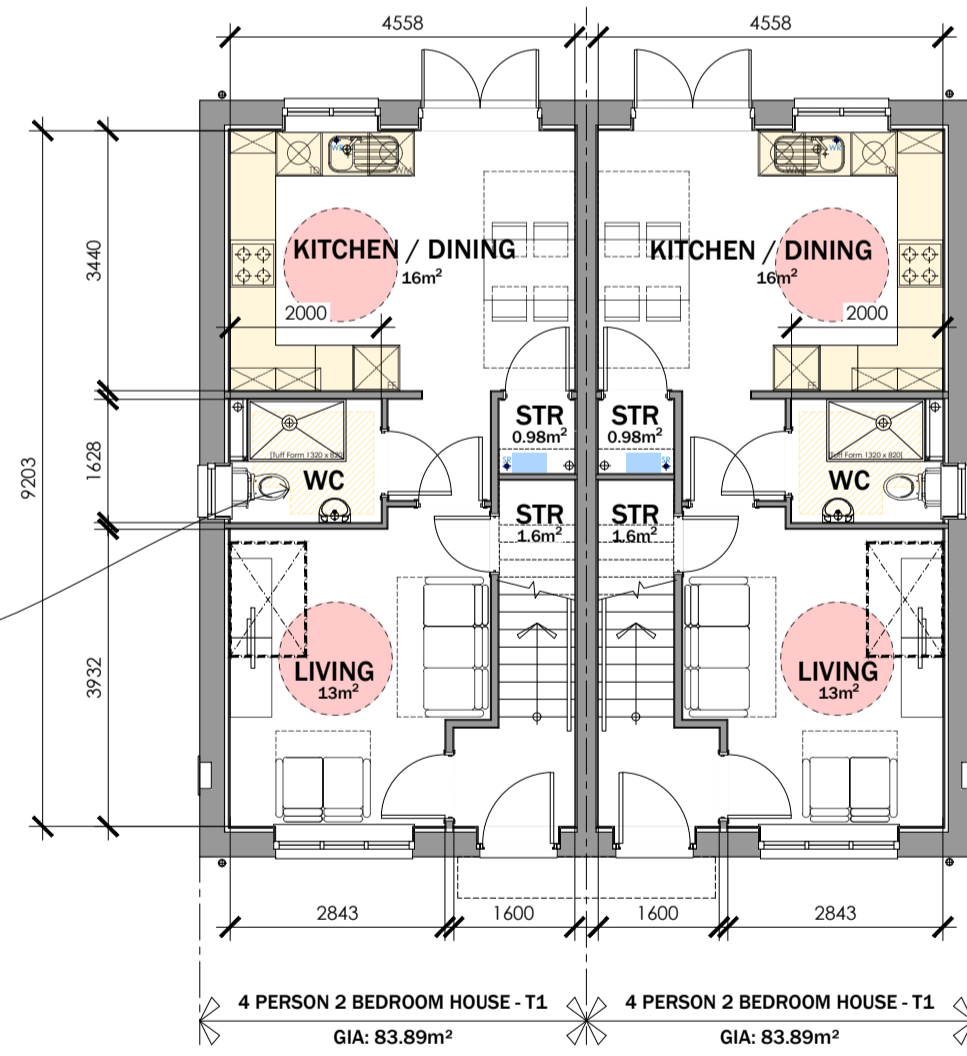

GROUND FLOOR PLAN

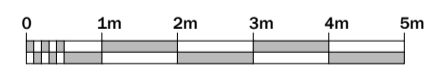

STORAGE SCHEDULE:
4P2B HOUSE TYPE 1
 GROUND FLOOR:
 STORE: 0.98M²
 U/S STAIRS: 1.60M²
 FIRST FLOOR:
 AC: 0.95M²
 STORE: 1.56M²
 TOTAL STORAGE PROVIDED - 4.59M²
 TOTAL STORAGE REQUIRED - 2.5M²
 TOTAL STORAGE EXCESS - 2.09M²



FRONT ELEVATION

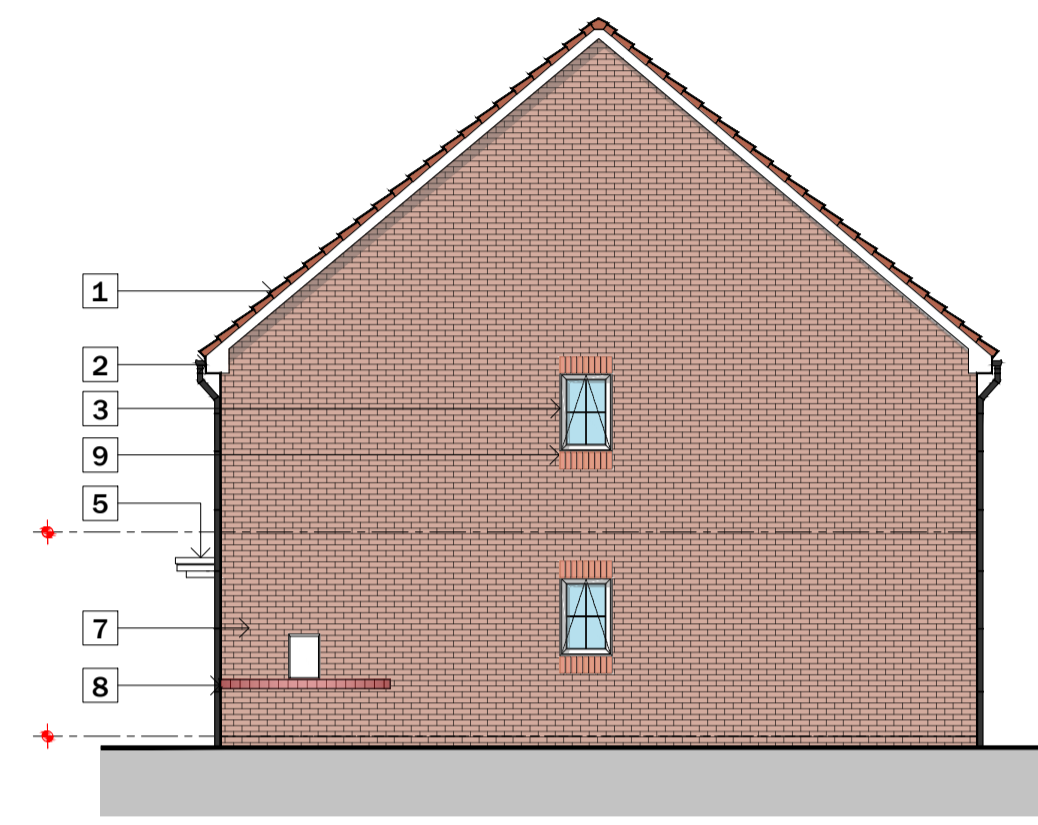

SIDE ELEVATION



REAR ELEVATION

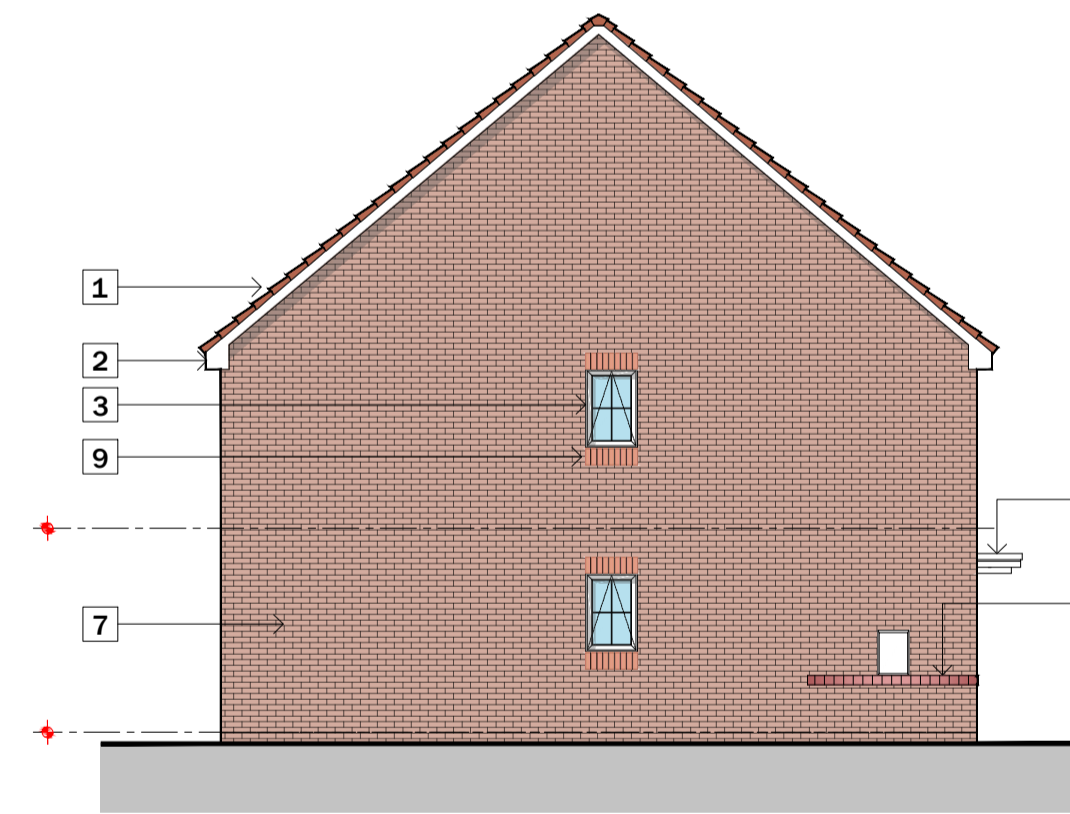
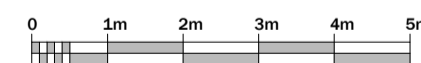

SIDE ELEVATION

MATERIAL KEY LEGEND

- 1 RECONSTITUTED SLATE ROOF FINISHES - DARK RED
- 2 WHITE UPVC FASCIAS, SOFFITES AND BARGEBOARDS WITH BLACK RAINWATER GOODS
- 3 WHITE UPVC DOUBLE GLAZED WINDOWS AND REAR DOOR
- 4 CREAMING TILE BRICK CILL
- 5 GRP PORCH CANOPY OVER
- 6 PREFABRICATED FLAT GAUGE BRICK ARCH IN SMOOTH DARK RED BRICKWORK
- 7 FACING BRICKWORK
- 8 PROJECTING BRICK FEATURE BAND AT 750MM ABOVE FFL IN SMOOTH DARK RED BRICK.
- 9 SOLDIER COURSE CILLS AND HEADS
- 10 ROUGH CAST RENDER FINISH COLOUR: OFF WHITE
- 11 GRP COMPOSITE FRONT ENTRANCE DOORS COLOUR: TBC

Do not scale from this drawing. The users of this drawing shall check all dimensions and details against the design and specifications of the design. This drawing is copyright. It must not be reproduced or used in any way without the prior permission of LeTrucco Design.

Revisions
SMALL ADJUSTMENTS TO ELEVATIONS

Drawing No	Revision	Scale	Date	Checked
LT2410.04.300	A	1:100 @ A1	Aug 24	KWL
Job Title	4P2B House Type - PLOTS 6 - 7			
Client	Newydd HA			
Job Title	Land off Hirwaun Road			

Drawing Purpose
PLANNING

4P 2B HOUSE TYPE 1
G.I.A = 83.89m² / 902.98 ft²

Plots 6 - 7